

# ARC CONCRETE MIRROR

800mm H x 500mm W - No Lighting



**Dimensions\*** Height: 800mm  
Width: 500mm  
Depth: 66mm

**Weight\*** 16kg

**Frame Material** Glass Fibre Reinforced Concrete

**Frame Finish** Satin - Low gloss

**Mount Type** Wall mounted with french cleat supplied. See mounting guide for details.

**Warranty** 2 years

**Lighting** No Lighting (option with LED backlighting also available)

FRONT VIEW

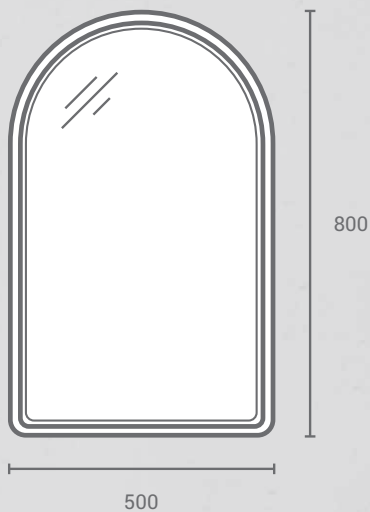

SIDE VIEW



BACK VIEW

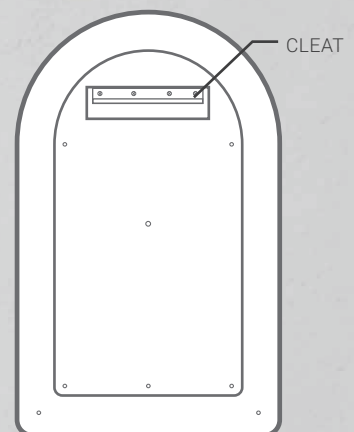

\* The dimensions and weight are nominal measurements only. Due to the nature of concrete, there may be slight variation in colour, finish and weight. For more details on the characteristics of concrete, please refer to our Qualities of Concrete Guide.

# ARC CONCRETE MIRROR

800mm H x 500mm W - LED Backlight



**Dimensions\*** Height: 800mm  
Width: 500mm  
Depth: 76mm

**Weight\*** 17kg

**Frame Material** Glass Fibre Reinforced Concrete

**Frame Finish** Satin - Low gloss

**Mount Type** Wall mounted with supplied french cleat/s.  
Both horizontal and vertical mounting cleats supplied. See mounting guide for details.

**Warranty** 2 years

**LEDs** 10W, 24V, Rapid Neoflex, 4000k IP67

**Driver** 30 W, 24VDC LED Dimmable Driver - IP20  
AS/NZS 61347.1, AS/NZS 61347.2.13, AS/  
NZS 60598.1, AS CISPR 15

FRONT VIEW

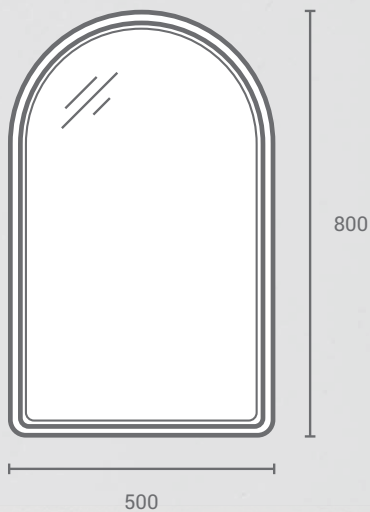

SIDE VIEW



BACK VIEW

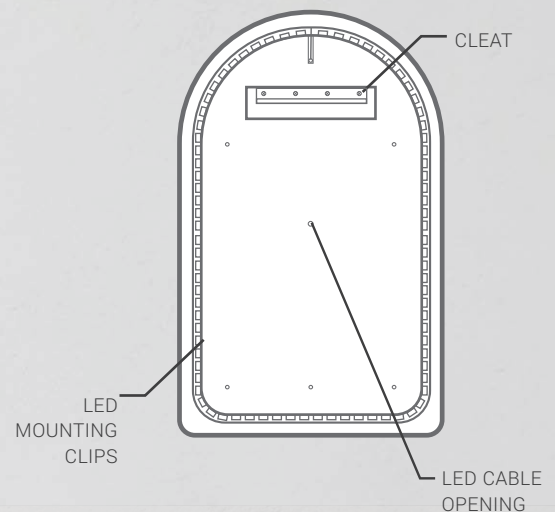

\* The dimensions and weight are nominal measurements only. Due to the nature of concrete, there may be slight variation in colour, finish and weight. For more details on the characteristics of concrete, please refer to our Qualities of Concrete Guide.

# ARC CONCRETE MIRROR

600mm H x 400mm W - LED Backlight



**Dimensions\*** Height: 600mm  
Width: 400mm  
Depth: 76mm

**Weight\*** 12kg

**Frame Material** Glass Fibre Reinforced Concrete

**Frame Finish** Satin - Low gloss

**Mount Type** Wall mounted with supplied french cleat/s.  
See mounting guide for details.

**Warranty** 2 years

**LEDs** 10 w 24v, Rapid Neoflex, 4000k IP67

**Driver** 20 W, 24VDC LED Dimmable Driver - IP20  
AS/NZS 61347.1, AS/NZS 61347.2.13, AS/  
NZS 60598.1, AS CISPR 15

FRONT VIEW



SIDE VIEW



BACK VIEW

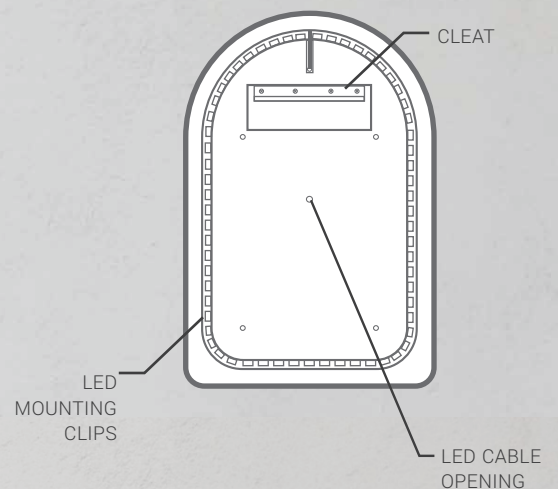

\* The dimensions and weight are nominal measurements only. Due to the nature of concrete, there may be slight variation in colour, finish and weight. For more details on the characteristics of concrete, please refer to our Qualities of Concrete Guide.

# ARC CONCRETE MIRROR

600mm H x 400mm W - No Lighting



**Dimensions\*** Height: 600mm  
Width: 400mm  
Depth: 64mm

**Weight\*** 11kg

**Frame Material** Glass Fibre Reinforced Concrete

**Frame Finish** Satin - Low gloss

**Mount Type** Wall mounted with french cleat supplied. See mounting guide for details.

**Warranty** 2 years

**Lighting** No Lighting (option with LED backlighting also available)

FRONT VIEW



SIDE VIEW



BACK VIEW

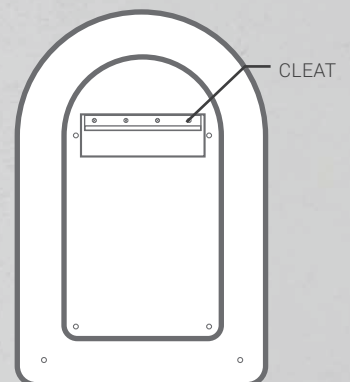

\* The dimensions and weight are nominal measurements only. Due to the nature of concrete, there may be slight variation in colour, finish and weight. For more details on the characteristics of concrete, please refer to our Qualities of Concrete Guide.